

## Particular Specification

Item No:	BMS-621MG
Weight:	47 grams / 1.66 oz.
Size:	40.5 x 20 x 38.5 mm / 1.60 x 0.78 x 1.54 in.
Torque At 4.8V:	6.4kg-cm , 89 oz-in
Torque At 6.0V:	7.2kg-cm , 109 oz-in
Speed At 4.8V:	0.13 sec / 60° at no load
Speed At 6.0V:	0.10 sec / 60° at no load
Ball Bearing:	Dual / M9x7
Metal Gears:	YES, 3 gears of aluminum, 2 gear of copper, 1 nylon gear
Motor Type:	Double magnetic motor
Operating Voltage Range	4.8V to 6.0V
Operating Temperature Range	-20°C to +60°C
Idle Current	5mA at Stopped
Running Current	420mA
Stall Current	1200mA
Dead Bend Width	6 usec
Direction	Re-clock wise / pulse traveling 1200 to 1600 usec
Horn Gear Spline	25 Segments / (Same as Futaba)
Connector Wire Length	300mm (11.81in)
Connector Horsing	Universal connector
Wire Info	Brown Wire = Battery Negative Red Wire = Battery Positive Orange Wire = Signal

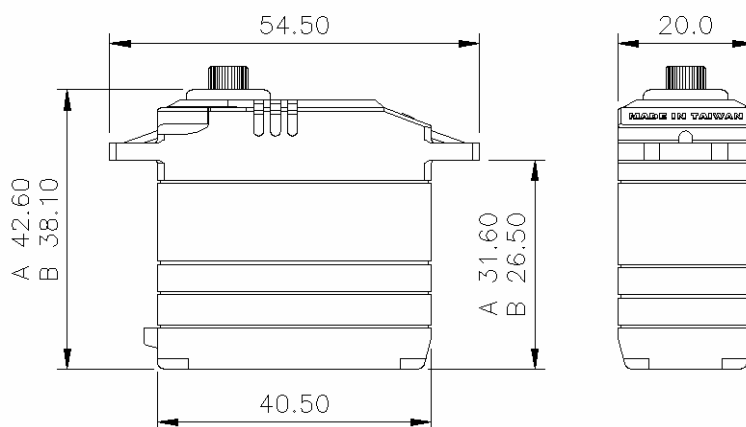

**Unit: mm**